

ML1200 Electromagnetic Lock

The ML series of electromagnetic locks are renowned for their excellent holding force and remarkable features.

The ML electromagnetic lock series are fully compliant to UL, CE and PSB tests and are manufactured under the highest quality control to achieve the commitment to customers who always demand the maximum quality and reliability.

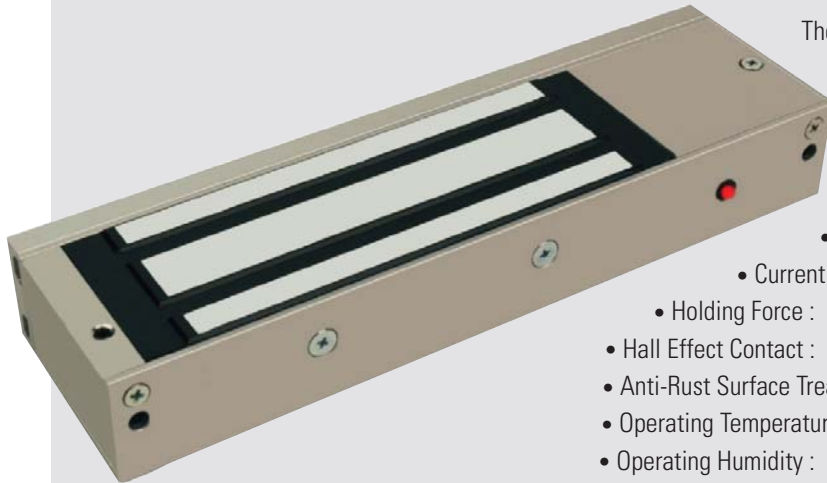

ML 1200LED Specifications

- Voltage Input : 12 VDC / 24 VDC
- Current Draw : 12V / 500mA ; 24V / 250mA (±5%)
- Holding Force : Up to 1200 lbs (545 kg)
- Hall Effect Contact : SPDT rated 2A at 24 VDC
- Anti-Rust Surface Treatment : Blue Zinc Plating
- Operating Temperature : 0~55° C (32~131° F)
- Operating Humidity : 0~95% (non condensing)
- Weight (Magnet) : 2.5 kg (±1%)
- Dimensions : Magnet - (L) 266mm x (W) 67mm x (D) 39 mm
Armature - (L) 185mm x (W) 61mm x (D) 16.5 mm

ML1200 Electromagnetic Lock Specifications

- _____ Dual Voltage Selectable (12 VDC or 24 VDC)
- _____ Low Current Consumption
- _____ Reliable Holding Force
- _____ Hall Effect Sensor Monitoring Output
- _____ Green/Red LED Indication for EM Lock Status
- _____ Durable and Silence Operation
- _____ Cosmeticize Anodized Aluminum Casing
- _____ Surge & Spike Protection PCB
- _____ Anti-Tamper Jam Nuts
- _____ Full Range of Optional Brackets
- _____ Anti Residual Magnetism Kick Off Button
- _____ EM Lock Energised EM Lock De-energised

ML Series comes in ML600LED, ML800G, ML1200LED, ML1200G and ML1500LED

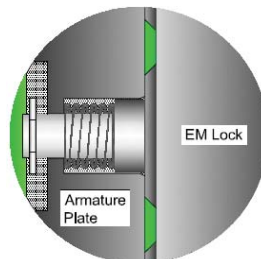
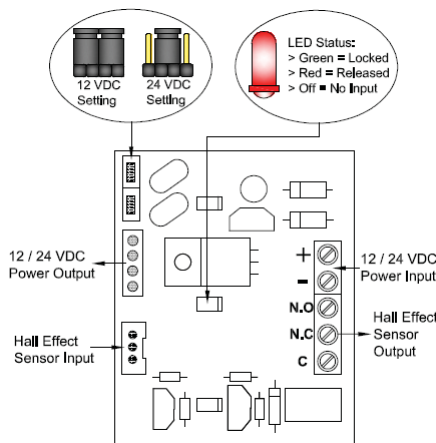

EM lock energised

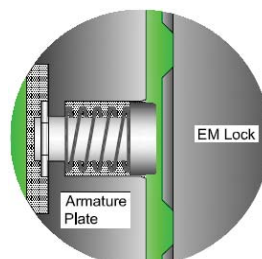

EM lock de-energised

ML600LED - Slim line magnetic lock (12/24v DC) with 600lbs (272kg) holding force, includes LED for lock/power status

ML800G - Stainless steel magnetic lock for external gates (12/24v DC) with 800lbs (362kg) holding force - monitored

ML1200G - Stainless steel magnetic lock for external gates (12/24v DC) with 1200lbs (545kg) holding force - monitored

ML1200LED - Magnetic lock (12/24v DC) with 1200lbs (545kg) holding force, includes LED for lock/power status - monitored

ML1500LED - Magnetic lock (12/24v DC) with 1500lbs (545kg) holding force, includes LED for lock/power status - monitored

ZL600LED - Z&L brackets to suit ML600LED

ZL800G - Z&L brackets to suit ML800G

ZL1200G - Z&L brackets to suit ML1200G

ZL1200LED - Z&L brackets to suit ML1200LED

ZL1500LED - Z&L brackets to suit ML1500LED

BitronVideo Group Ltd

6 Oak Industrial Park
Chelmsford Road
Great Dunmow
Essex CM6 1XN

T: 01371 871585

F: 01371 871584

E: sales@bitronvideo.co.uk

W: www.bitronvideo.co.uk